

Bottom Blowdown Valve

BKV 4000

Installation and Operating Instructions

EN

English

NOTES

A series of 26 horizontal dotted lines intended for handwritten notes.



CONTENT

1.SAFETY INFORMATION	II
2.GENERAL INFORMATION	1
2.1 Description	1
3.TECHNICAL SPESIFICATONS	2
3.1 Dimensions.....	2
3.2 Mechanical Spesifications	2
3.3 BLS 4000 Limit Switch.....	3
3.4 BNR 4000 Namur Solenoid Valve	3
4.INSTALLATION AND WIRING	3
4.1 Installation.....	4
4.2 Wiring	5
5.COMMISSIONING	6
6.MAINTANANCE	6

1. SAFETY INFORMATION

Installation, commissioning and maintenance of this device must be done by a qualified personnel in compliance with the operating instructions. Otherwise device and related equipments may be damaged and personnel may be injured. General installation and safety instructions for pipeline and plant construction, as well as the proper use of tools and safety equipment must also be complied with.

National and local regulations must be taken into consideration.



Warning!

Please make sure to remove the main supply before installation. Otherwise this may cause damage to the product, personal injuries or even death

1.1 Tools

Before starting work, make sure that you have suitable tools and consumables available.

1.2 Temperature

Let the temperature to cool down after isolation to avoid danger of burns.

1.3 Freezing

Required precautions must be taken at the places where they may be exposed to temperatures below freezing point.

1.4 Lighting

Make sure there is enough lighting, particularly where detailed or tough work is required.

1.5 Pressure

Make sure that any pressure is isolated and safely vented to atmospheric pressure. Do not assume that the system has depressurised even when the pressure gauge indicates zero.

1.6 Access

Before attempting to work on the product, safe Access must be ensured. If necessary, lifting gear should be used.

1.7 Residual hazards

The external surface of the product may be very hot. If used at the maximum operating conditions according to the specs, the surface temperature of some products may reach temperatures of 239°C.

1.8 Hazardous environment

Plant rooms are usually explosion risk areas. There may be lack of oxygen, dangerous gases extremes of temperature, hot surfaces, fire hazard excessive noise, moving machinery.

1.9 Suitable protective clothing

In order to be protected against the hazards of chemicals, high temperature, radiation, noise, falling objects, and dangers to eyes and face, anyone around requires protective clothing suitable in the plant room.

1.10 Hazardous liquids or gases

Be aware of that it cannot be known what may have been in the pipeline at previous usage. Consider: flammable materials, substances hazardous to health, extremes of temperature.

1.11 Supervision

All work must be carried out or be supervised by a suitably competent person. Installation and operating personnel should be trained in the correct use of the product according to the Installation and Operation Instructions.

1.12 Disposal

Unless otherwise stated in the Installation and Operation Instructions, this product is recyclable and no ecological hazard.

1.13 Returning products

When returning products to Vira Isı ve Endüstriyel Ürünler A.Ş the customers must provide information on any hazards and the precautions to be taken due to contamination residues or mechanical damage which may present a health, safety or environmental risk.

2.GENERAL INFORMATION

2.1 Description

Some impurities and salts (rust, oil and dirt that may come from the installation) precipitate to the bottom of the boiler to form a sludge layer. Thus, the heat transfer capability of the boiler is reduced and there is a danger of corrosion in the boiler. These foreign substances and salts should be periodically disposed out of the boiler to prevent the formation of the settling layer. For this, Automatic Bottom Blowdown Systems are used.

Automatic Bottom Blowdown system provides key operated manual control and full automatic control. It prevents waste of water and boiler water chemicals, therefore fuel and energy losses because of too much blowdown. Blowdown can be performed at desired ranges and times.

Bottom Blowdown Control Valve BKV 4000 opens and closes depending on the signals from the Bottom Blowdown Controller BK 4000 and ensures that the suspended or/and deposited solids and water removed from the bottom of the boiler.

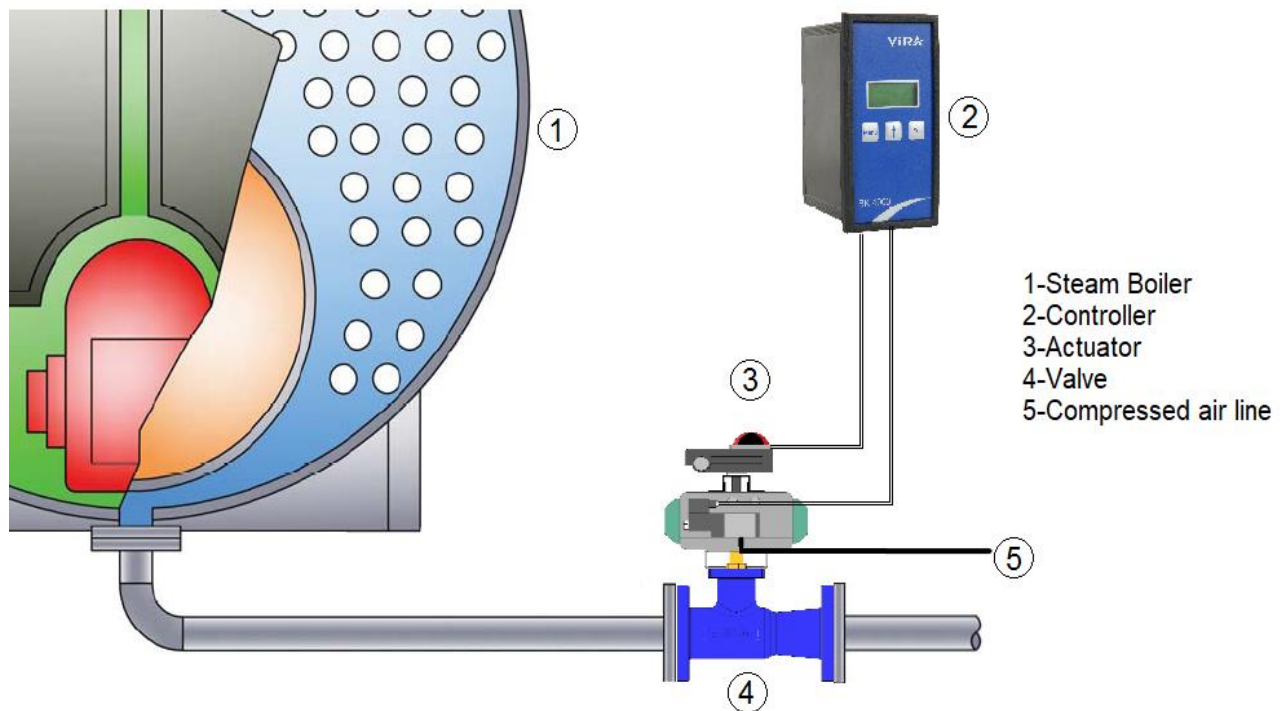

Figure 1: Connection of Bottom Blowdown System DB2 to a steam boiler

The BKV4000 is a spring return pneumatic actuated bottom blowdown valve with switch box and namur valve on it. By limit switch, it can be recognized if the valve is open or closed. It basically allows removing precipitated solids that could otherwise build up and eventually cause damage.

3. TECHNICAL SPECIFICATIONS

3.1. Dimensions (mm)

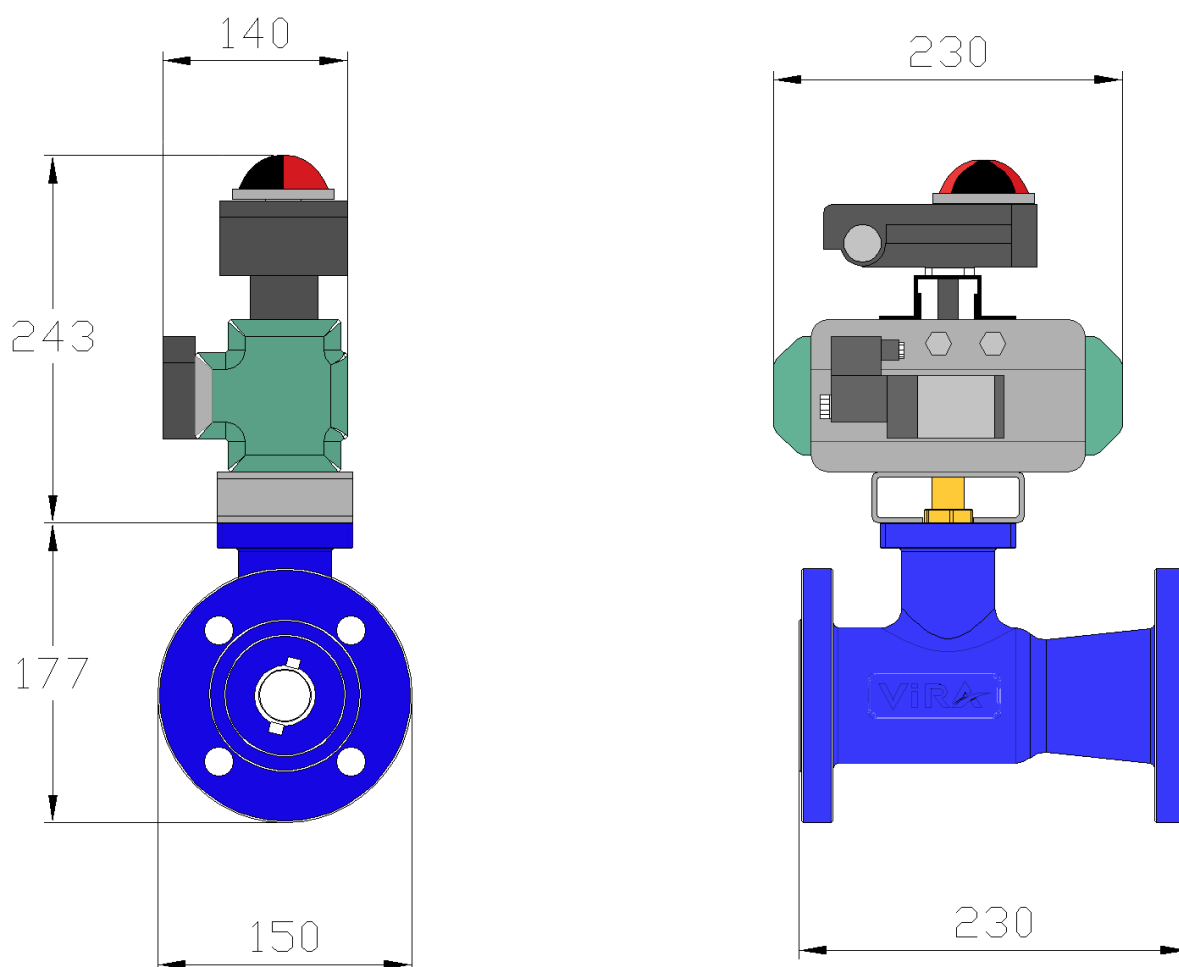

Figure 2: Dimension of Bottom Blowdown Valve BKV4025

3.2. Mechanical Specifications

Maximum operating temperature	: 224°C
Maximum operating pressure	: 25 bar g
Nominal pressure	: PN 25
Valve body	: GGG40 (Ductile iron casting)
Connection	: Flanged
Operation mode	: Spring return pneumatic actuator

3.3. BLS 4000 Limit Switch

Type	: 2 microswitches, open/close indicator
Enclosure	: IP 65
Maximum ambient temperature	: 80 °C
Weight	: 150 gr

3.4. BNR 4000 Namur Solenoid Valve

Type	: 1/4'' - 5/2
Supply voltage	: 24 V, 220 V
Maximum ambient temperature	: 80°C
Operation pressure	: 6-8 bar
Weight	: 250 gr

4. INSTALLATION AND WIRING

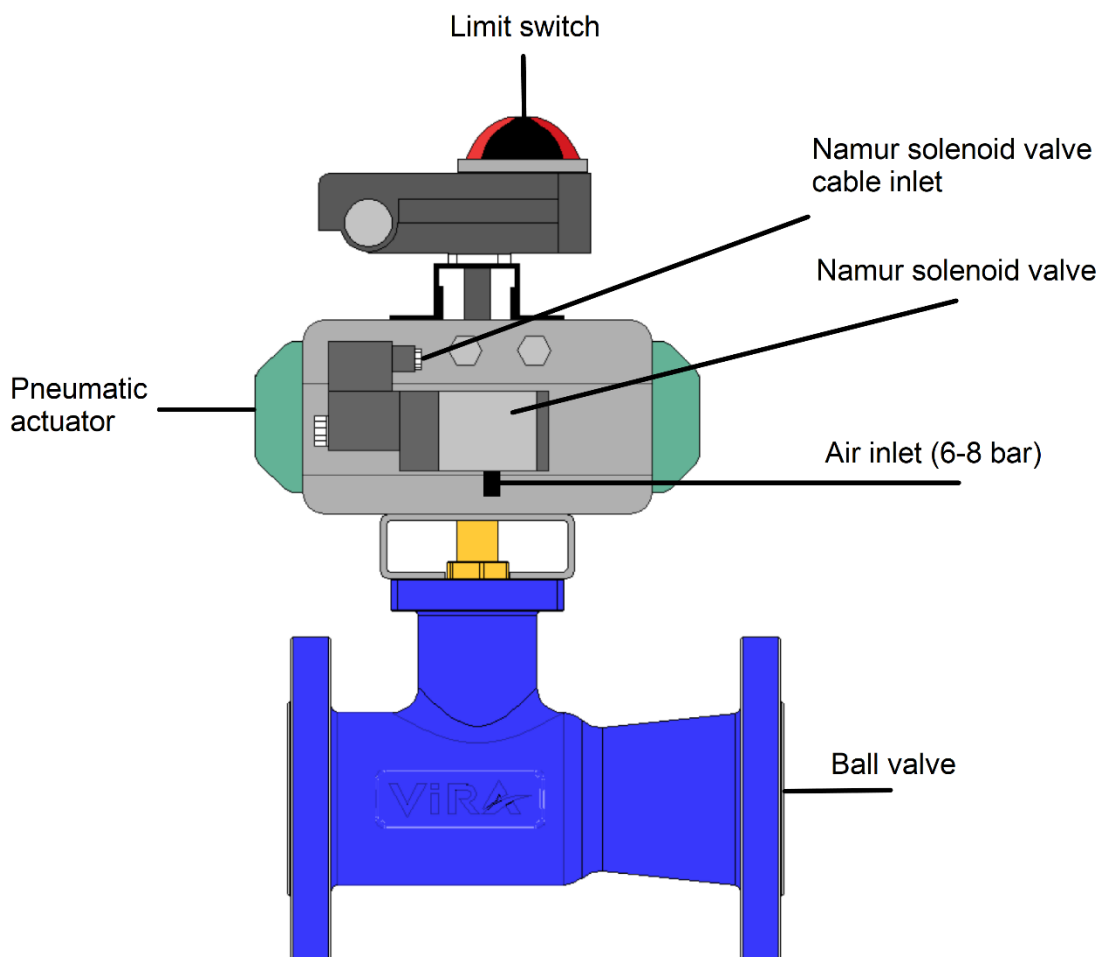

Figure 3: General view of BKV 4000 Bottom Blowdown Control Valve

4.1 Air Connection

Air connection can be made to port shown in Figure 3 with 1/4" pneumatic tube fitting like in Figure 3.



Figure 4: BNR 4000 Namur Solenoid Valve

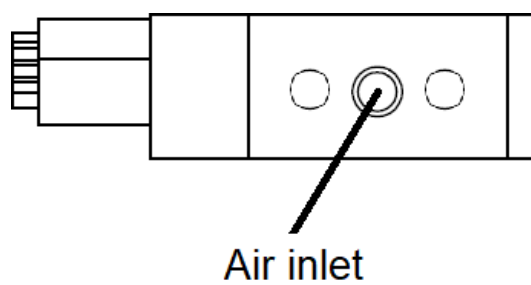

Figure 5: Bottom view of BNR 4000 and air inlet port

4.2 Wiring

Remove the screws on the limit switch and remove the cover. Wiring can be made with 2x1 mm² normal cable.

Remove the screw and open the namur solenoid valve cable inlet cover. Wiring can be made with 2x1 mm² normal cable.

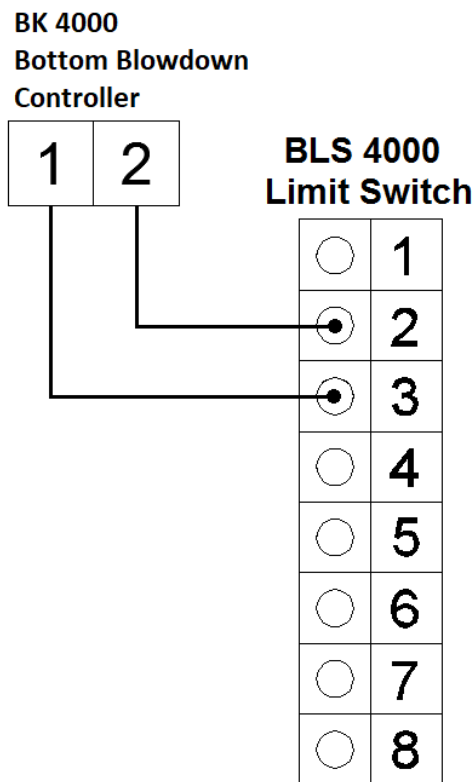

Figure 6: Wiring between controller and Limit Switch

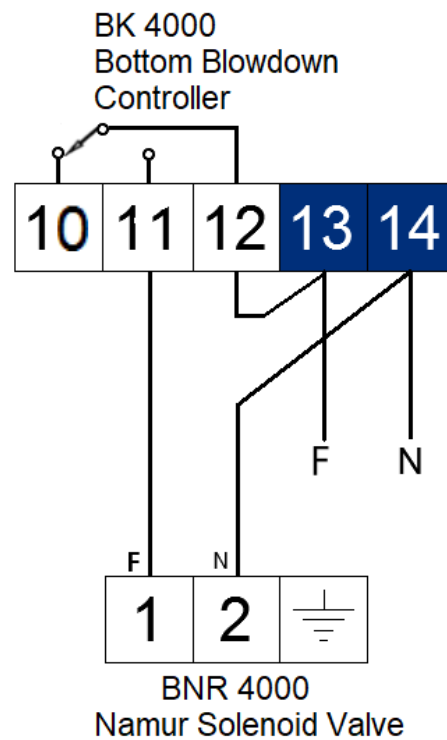

Figure 7: Wiring between controller and namur Solenoid valve

Limit Switch: Limit switch gives “valve opened” and “valve closed” signals to BK 4000.

Namur Solenoid Valve: It opens and closes the valve using the signals sent from BK 4000.

5. COMMISSIONING

- Make sure that all cable connections and air connection are right.
- After the air connection, press the blue button (2) shown in Figure 4 on the namur solenoid valve to check that the valve is opened and closed
- Make sure that controller operates the valve properly. To make this check please refer to “BK 4000 TDS Blowdown Controller Installation and Operating Instructions”.

6. MAINTENANCE



Warning!

The device may not be repaired and / or maintained except by authorized service personnel. If necessary, please contact ‘Vira Isi Service Department’.

If leakage occurs in the valve, leakage can be repaired by tightening the packing screw.

Tel : +98 911 229 5936

E-mail : info@fiammac.com
: vira.sales@fiammac.com

Web : www.viraisi.ir

NOTES

A series of 25 horizontal dotted lines for taking notes.